

PRACTICAL DIVIDING

THERE are several methods of dividing that require only hand tools or the normal equipment of a lathe. Most problems of division can be solved through one or other of them, or by combining two or more; and though the time taken may be longer than if one had proper equipment, the results need not suffer, given care in the work.

A protractor which is marked in degrees can be used for some jobs, and a number can be performed by geometry, with a rule, scribe, dividers, and centre punch. Divisions which can be easily obtained in this way are two, three, four, six, eight and twelve.

Any line across a circle gives two divisions, and another line at right-angles gives four. The second line is located geometrically as at A. A light dot is made with a centre punch at P and another at Q. Using these points to locate dividers, you scribe small arcs outside the circle, and join the

diameter of the circle ST in inches, gives you, as a straight line, the length TU to which the dividers must be set. When this has been done, the dividers can be stepped round the circumference of the circle, as when a circle is divided into six.

Small parts can sometimes be mounted in a piece of bar for marking-off, milling or grinding to common divisions such as two, three, four and six, and square and hexagon blocks

divisions. For two more at right-angles, the bar can be set by a square.

Three-jaw and four-jaw lathe chucks can be used for marking-off common divisions, as at D, on flat-bed lathes. On others, flat baseplates must be used to bridge the Vs. A support is machined to hold one jaw horizontal (1), while the work is scribed at both sides; or the support can be moved to the opposite side (2), so that a pointed tool can be employed from

By GEOMETER

points where they intersect by a scribed line which crosses the first at right-angles. With each of the four points used for further bisections, the circle can be divided into eight.

To divide a circle into six, the dividers are left at the setting for radius and are stepped round the circumference. Three divisions are obtained by taking every point; and by bisecting from each of the six points, twelve divisions are obtained.

Problems which involve odd divisions can be solved with a protractor or by trigonometry. When a protractor is used, care must be taken to keep its centre to the centre of the circle, or the point of origin of the arc: but with trigonometry, the only tricky job is setting the dividers. This must be done by a micrometer or steel rule. Diagram A shows the principle by which any division can be obtained for any circle.

First, the number of divisions is divided into 360 for the angle of arc R in degrees. You then halve this angle and look up the fraction for the half-angle in the column of sines. Multiplying the fraction by the

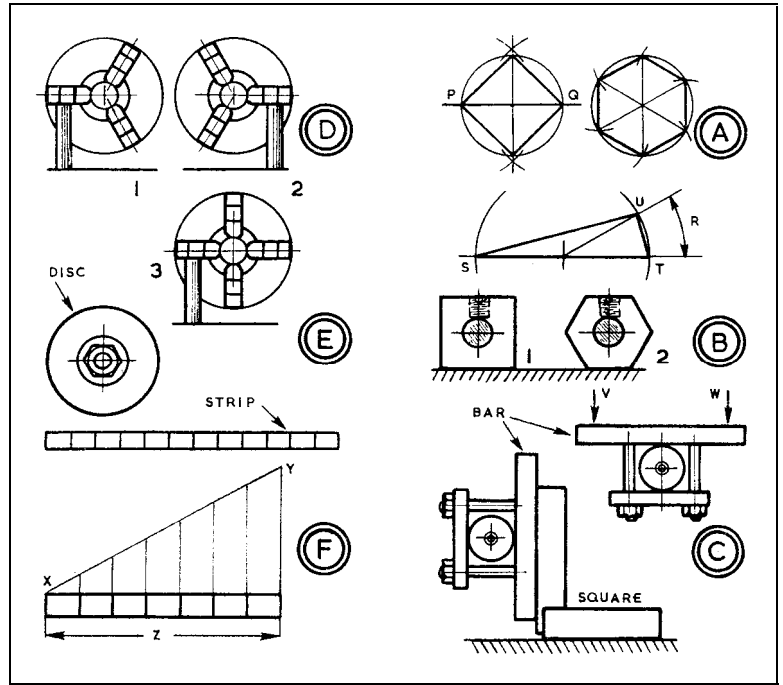

can be used as at BI and 2. After a part has been mounted, the block can be turned to its different faces and clamped for succeeding operations—which is usually easier and provides more accurate results than locating and holding the part itself.

Diagram C shows another way which provides two or four divisions for work mounted between centres? on a lathe or bench. Clamp a straight bar to the work and set it horizontal by checking with a surface gauge or indicator at V and W. This gives two

the slide. Using all three jaws at both positions, you obtain six divisions. A four-jaw chuck (3) gives four.

Any number of divisions can be obtained on a disc as at E—for the disc to be mounted to work. The strip carries equally-spaced divisions, and its length is divided by 3.1416 to provide the diameter for the disc. If both are of metal, they can be tacked with solder. Diagram F shows how you can divide a strip of given length, marking divisions on a sloping length XY and projecting to length Z.