

**AR BIHAN**

**Mono 4 temps - Alésage 12 mm - Course 15 mm**

**Soupape d'admission automatique**

**Soupape d'échappement commandée**

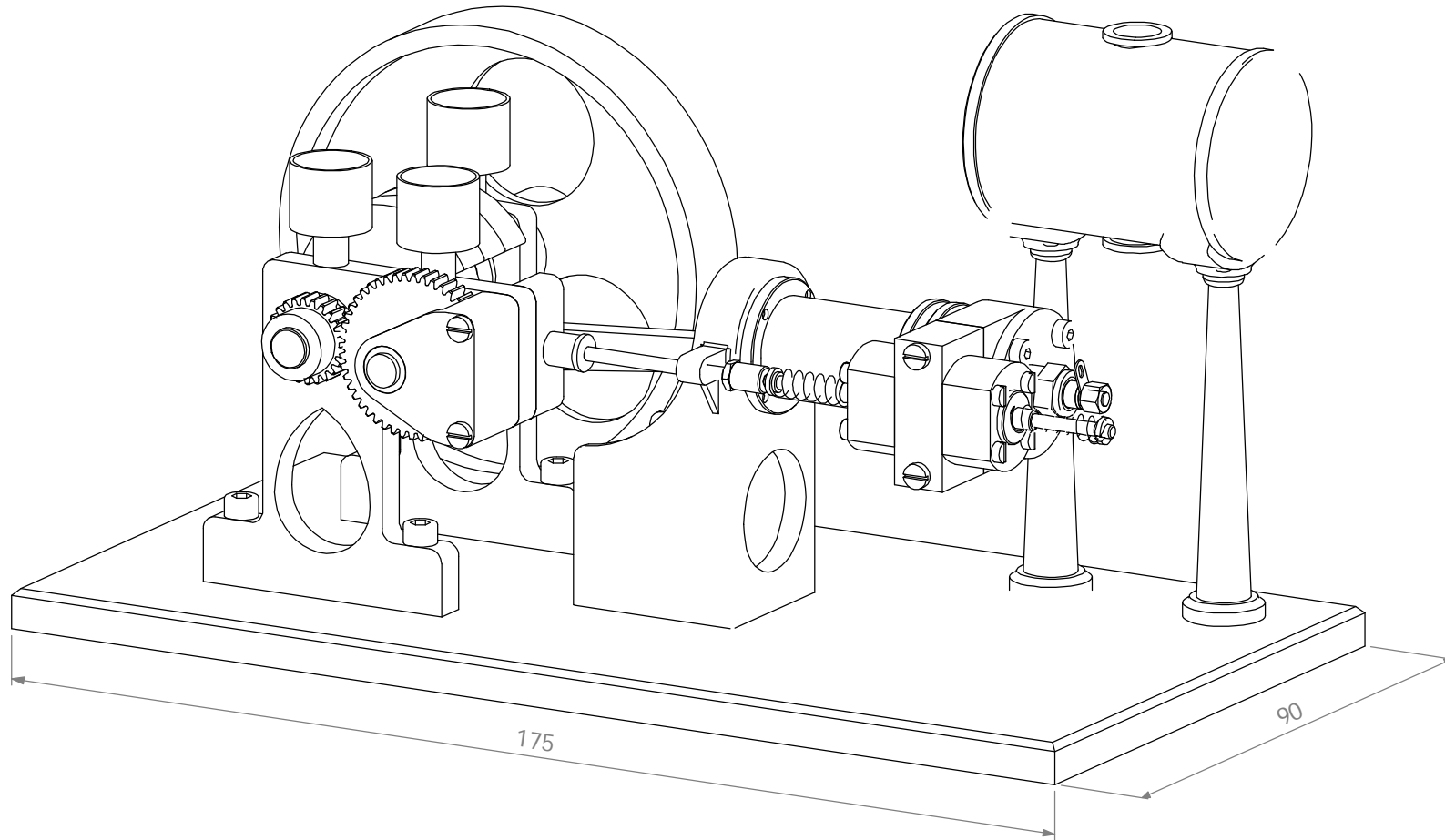

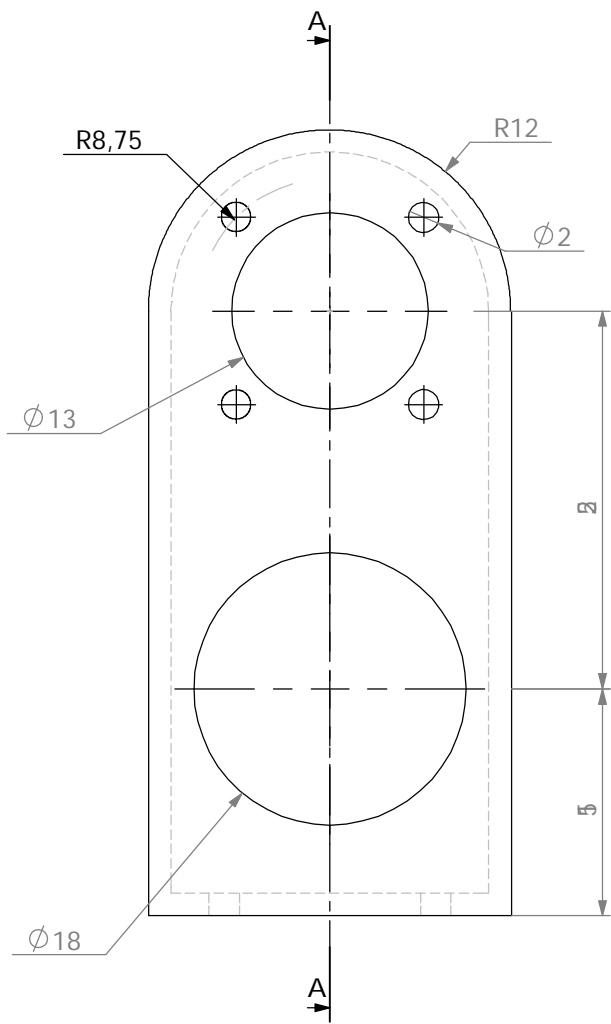

Support de cylindre

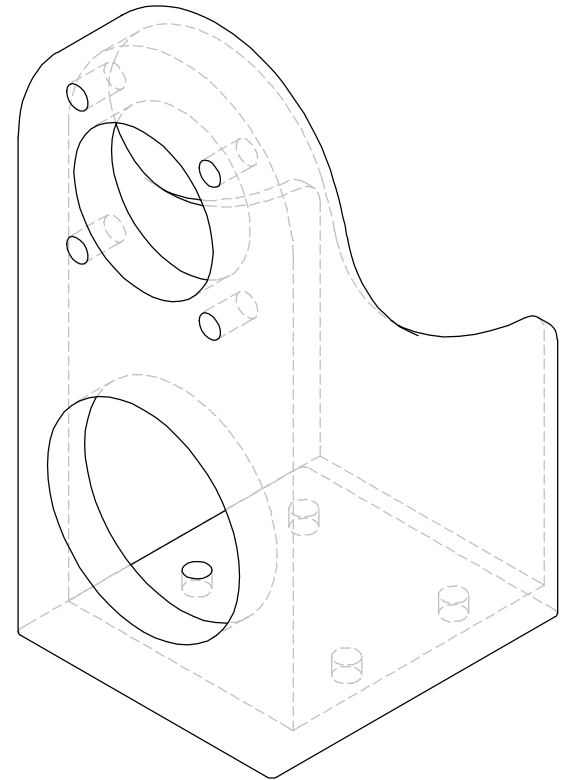
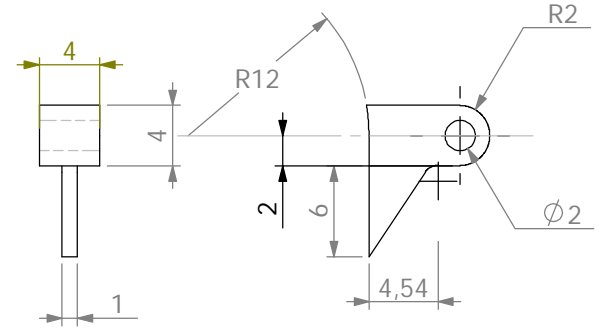
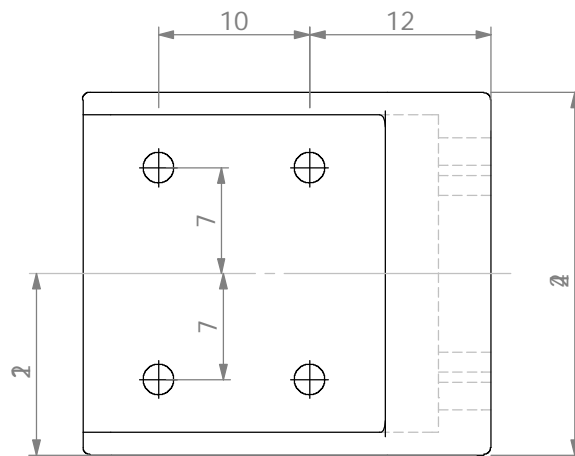
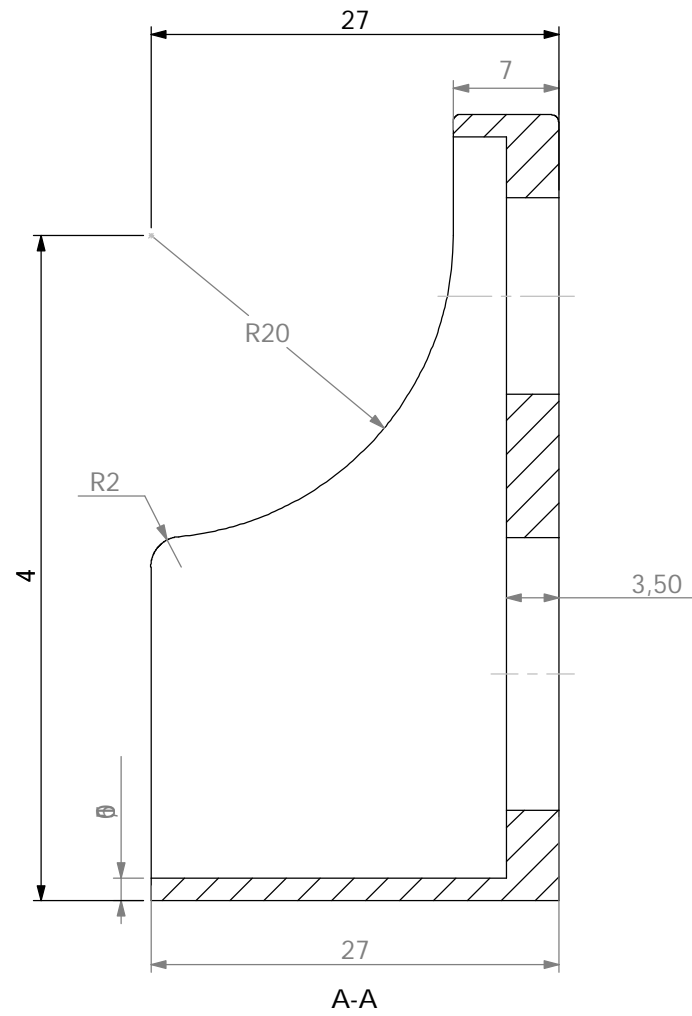

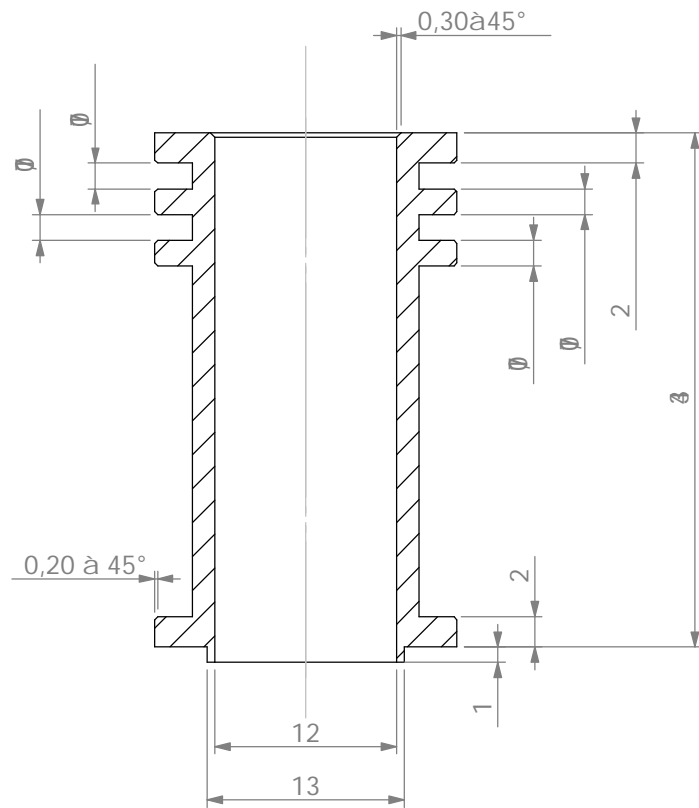
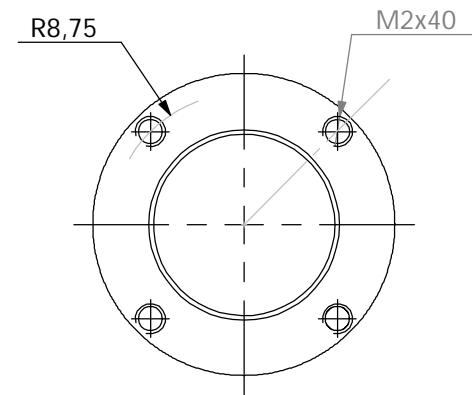
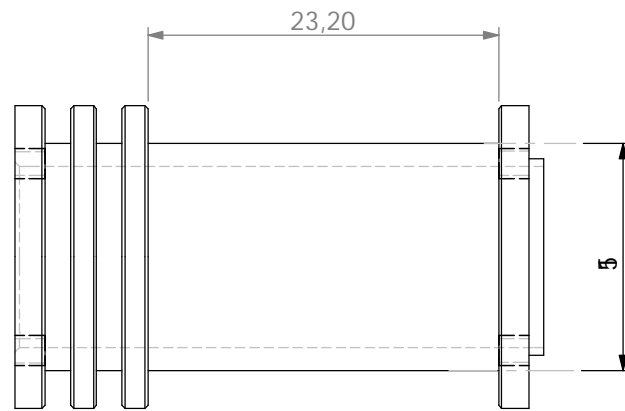
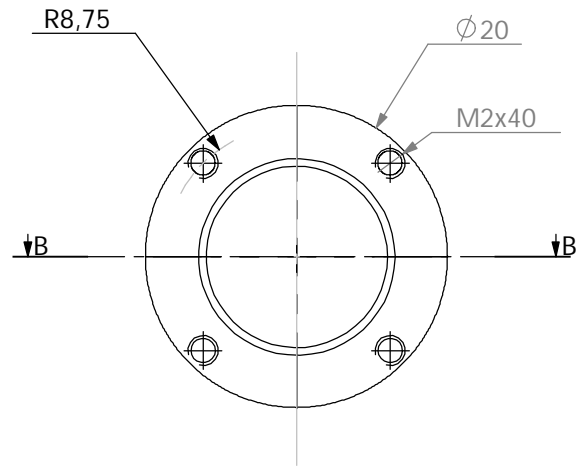

B-B

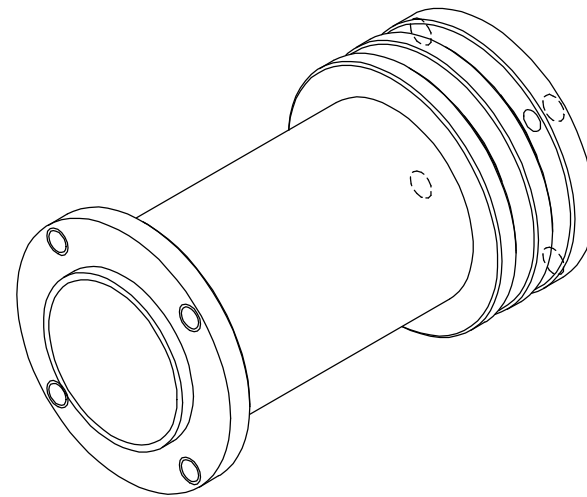

Cylindre

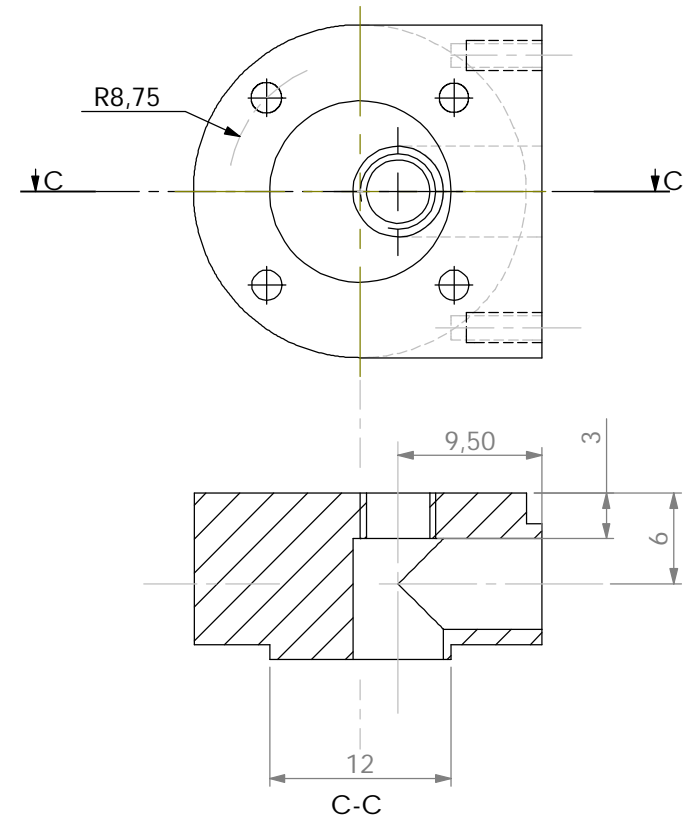
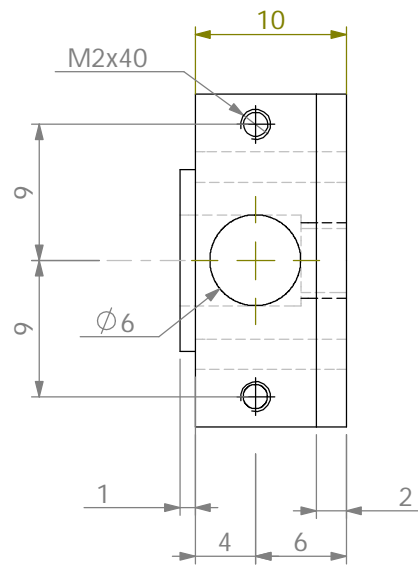
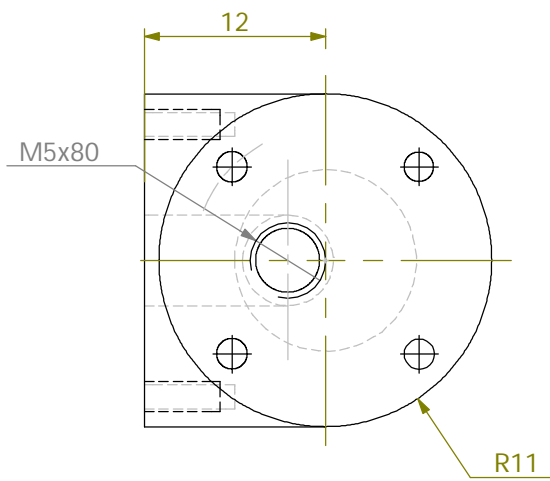

Culasse

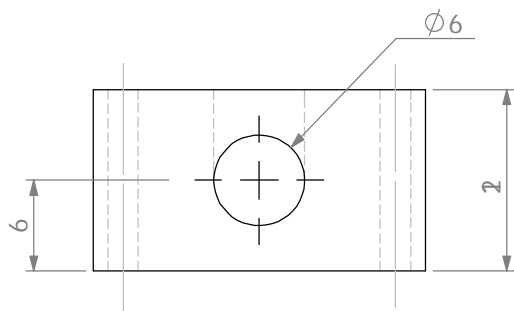
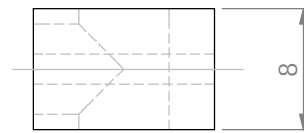
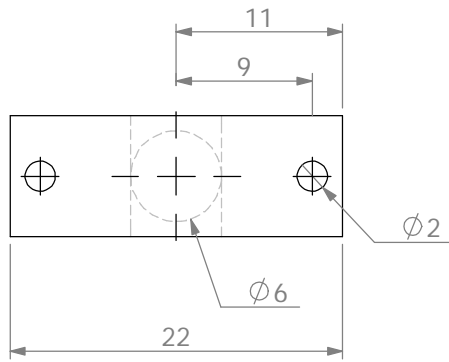

Bloc transfert

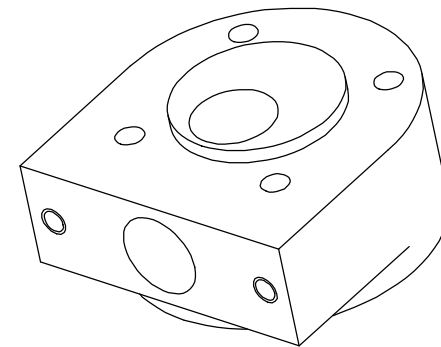

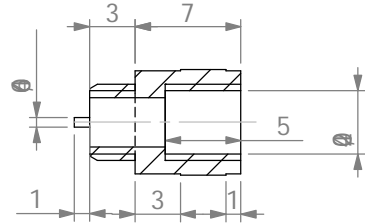
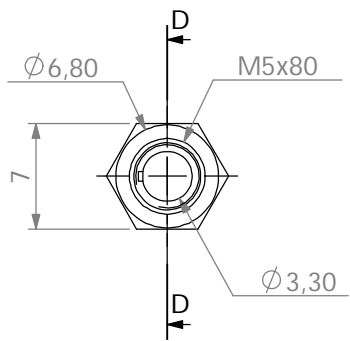

D-D

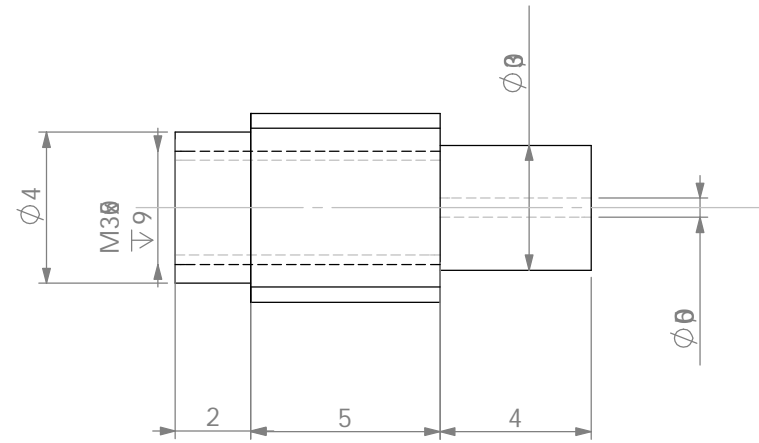
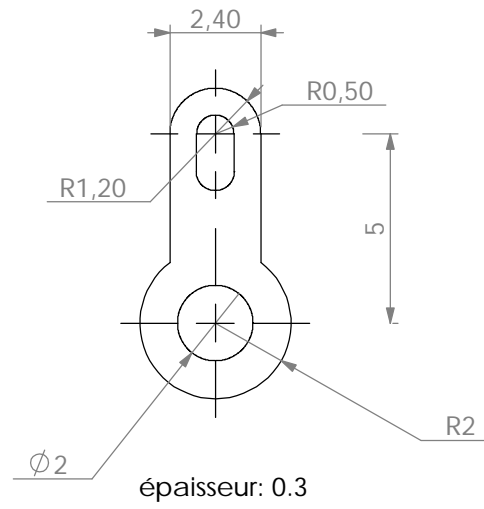
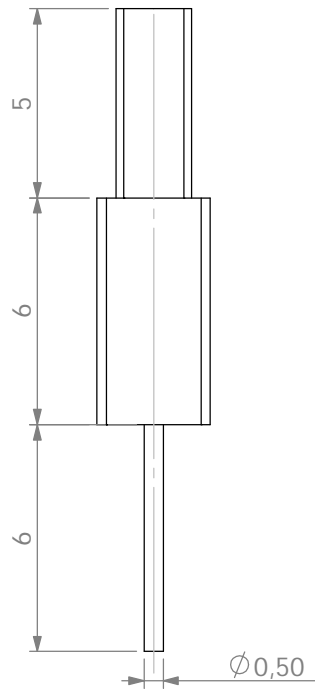
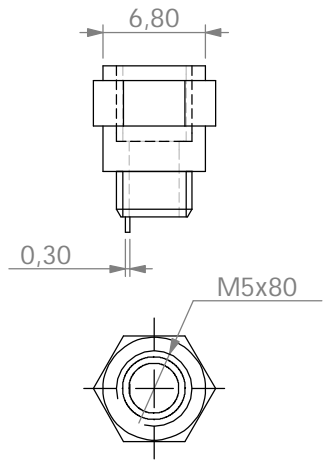
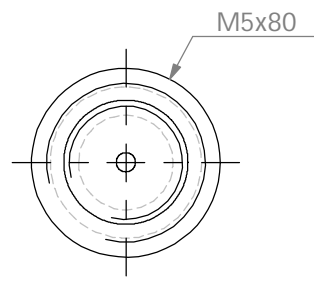

Ensemble bougie

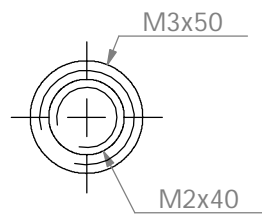

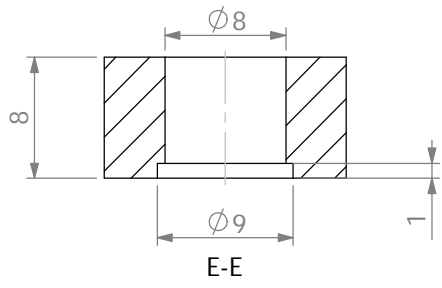

E-E

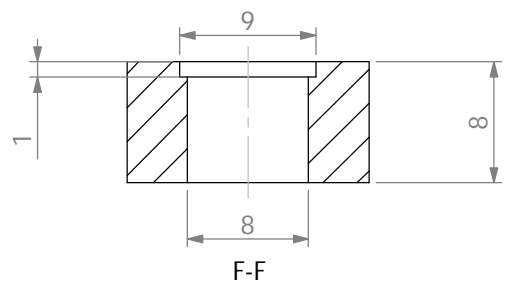

F-F

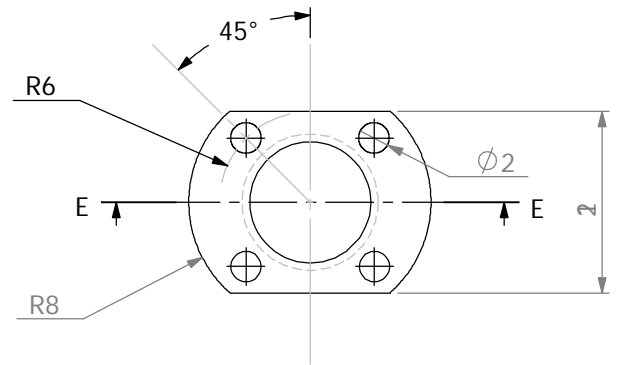

Bloc admission

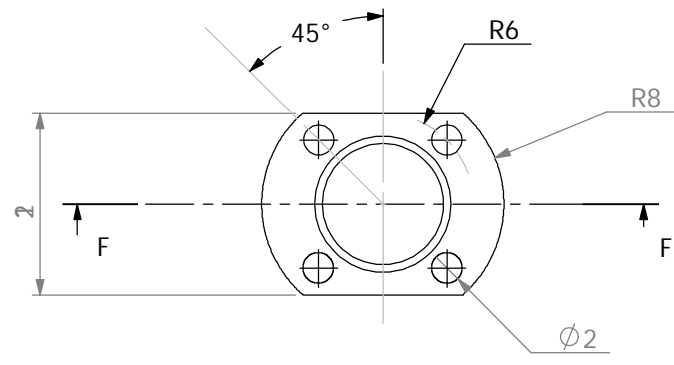

Bloc echappement

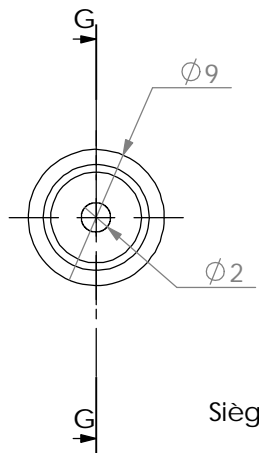

Siège de soupape

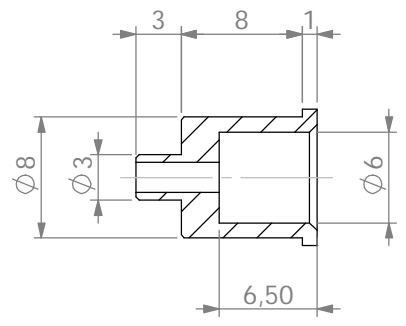

G-G

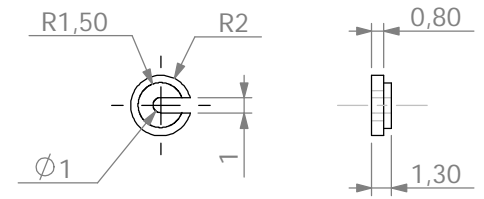

Coupelle

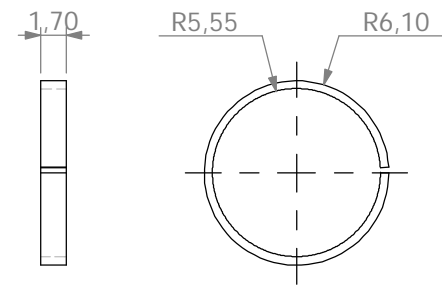
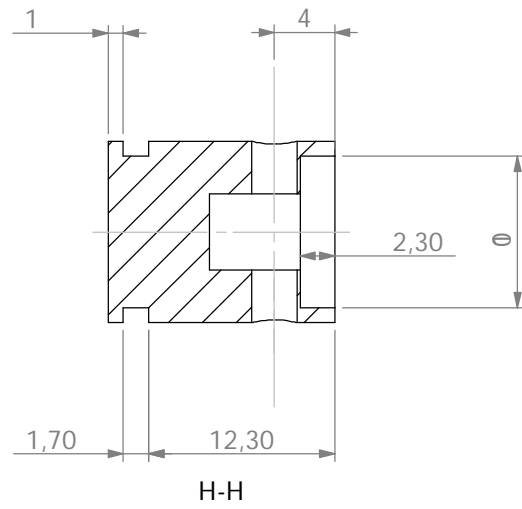
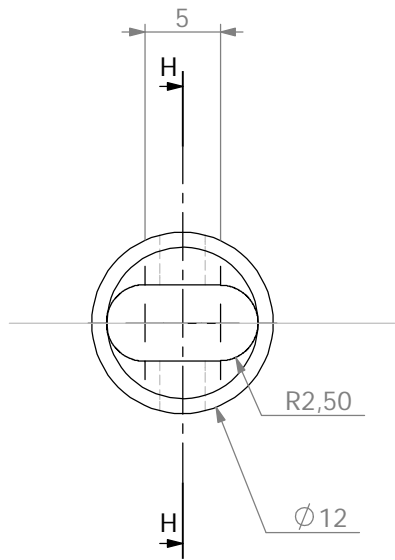

Segment

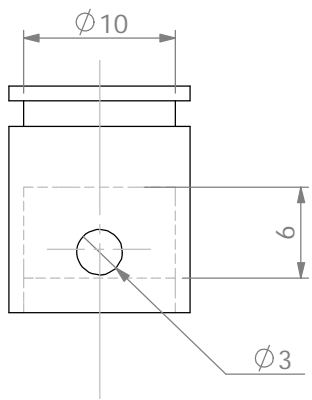

Piston

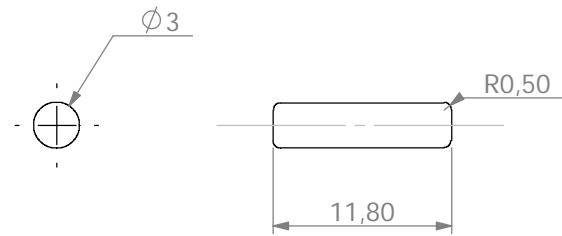
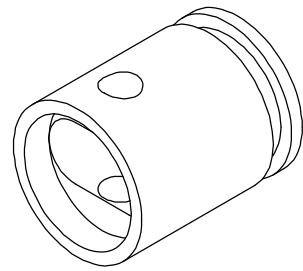

Axe de piston

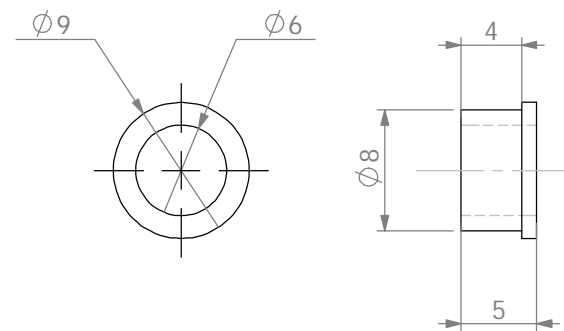
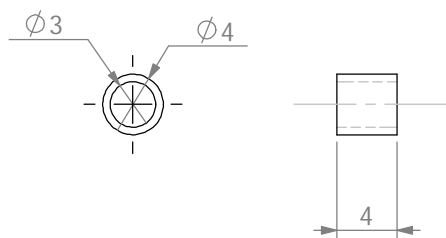
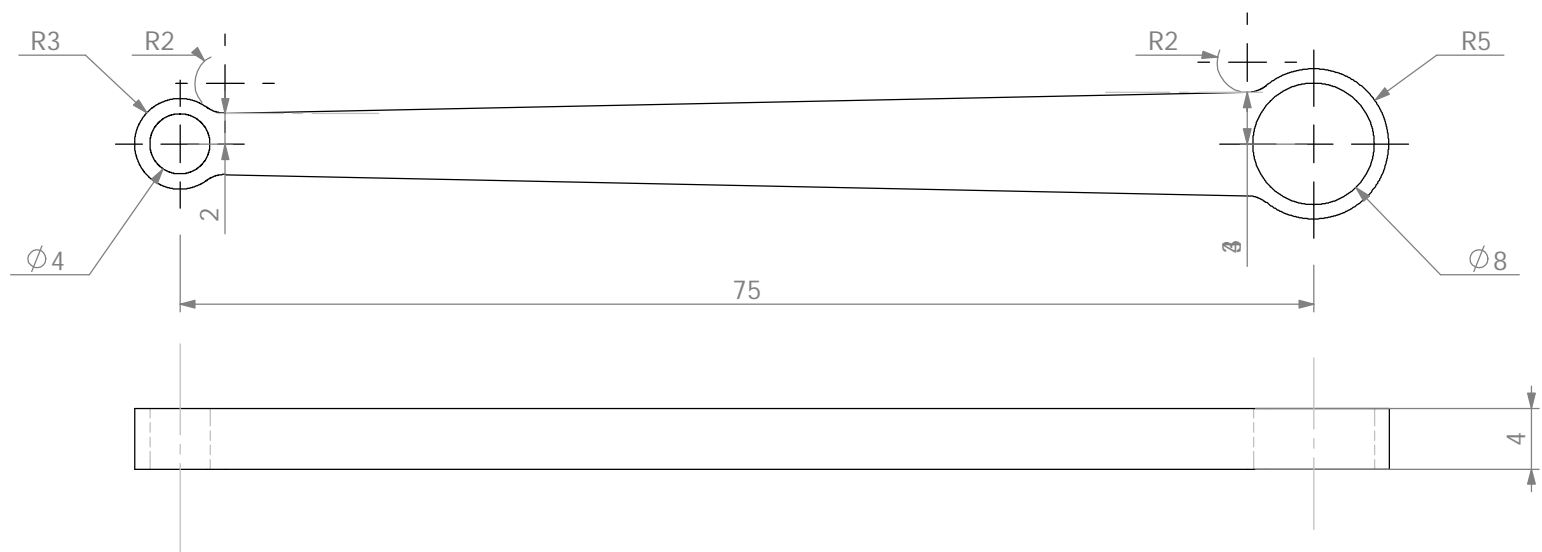

Bielle et coussinets de bielle

Volant

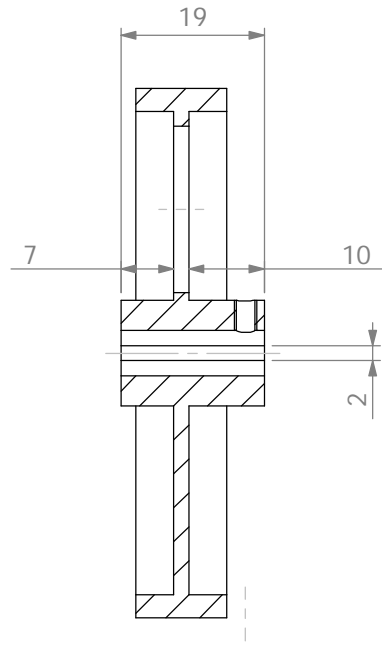

I-I

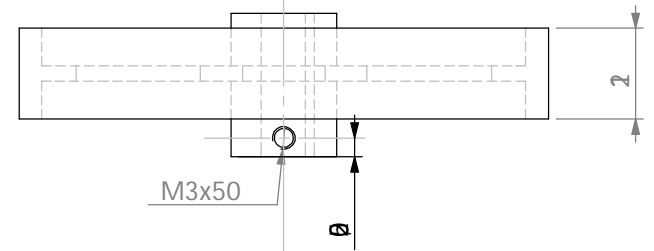
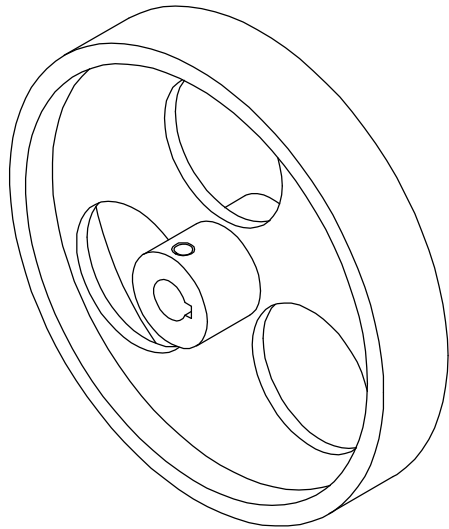
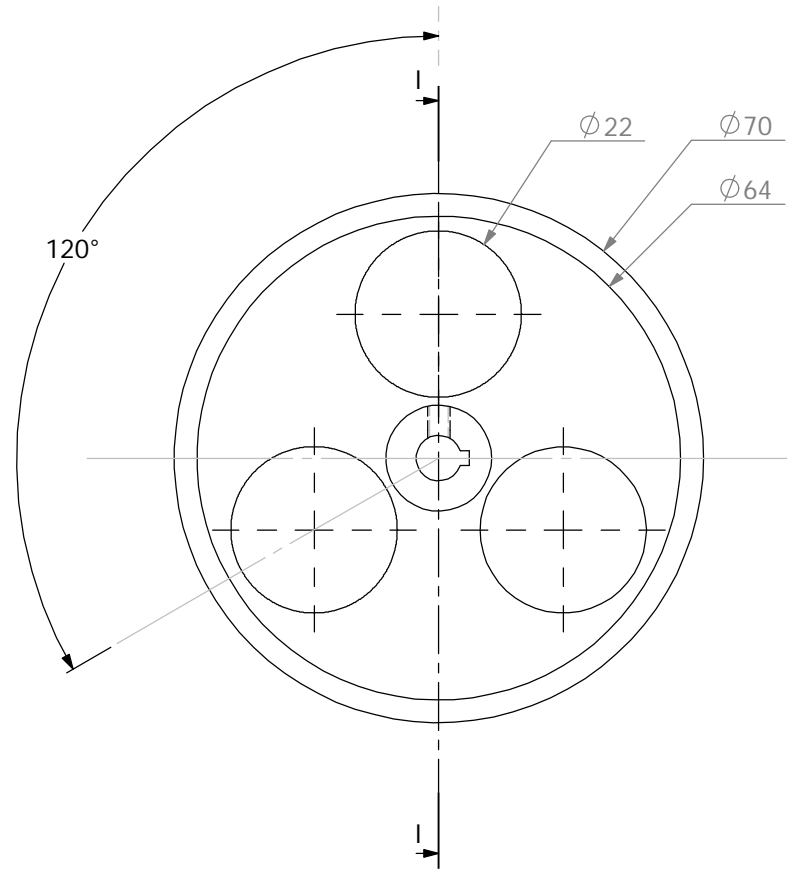

M3x50

$\phi$

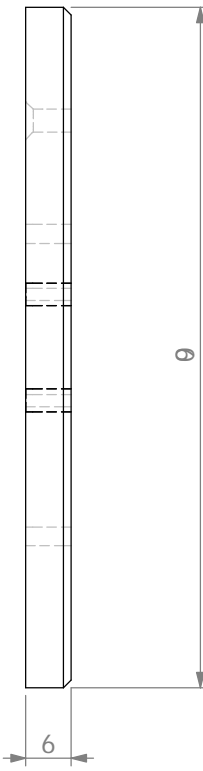
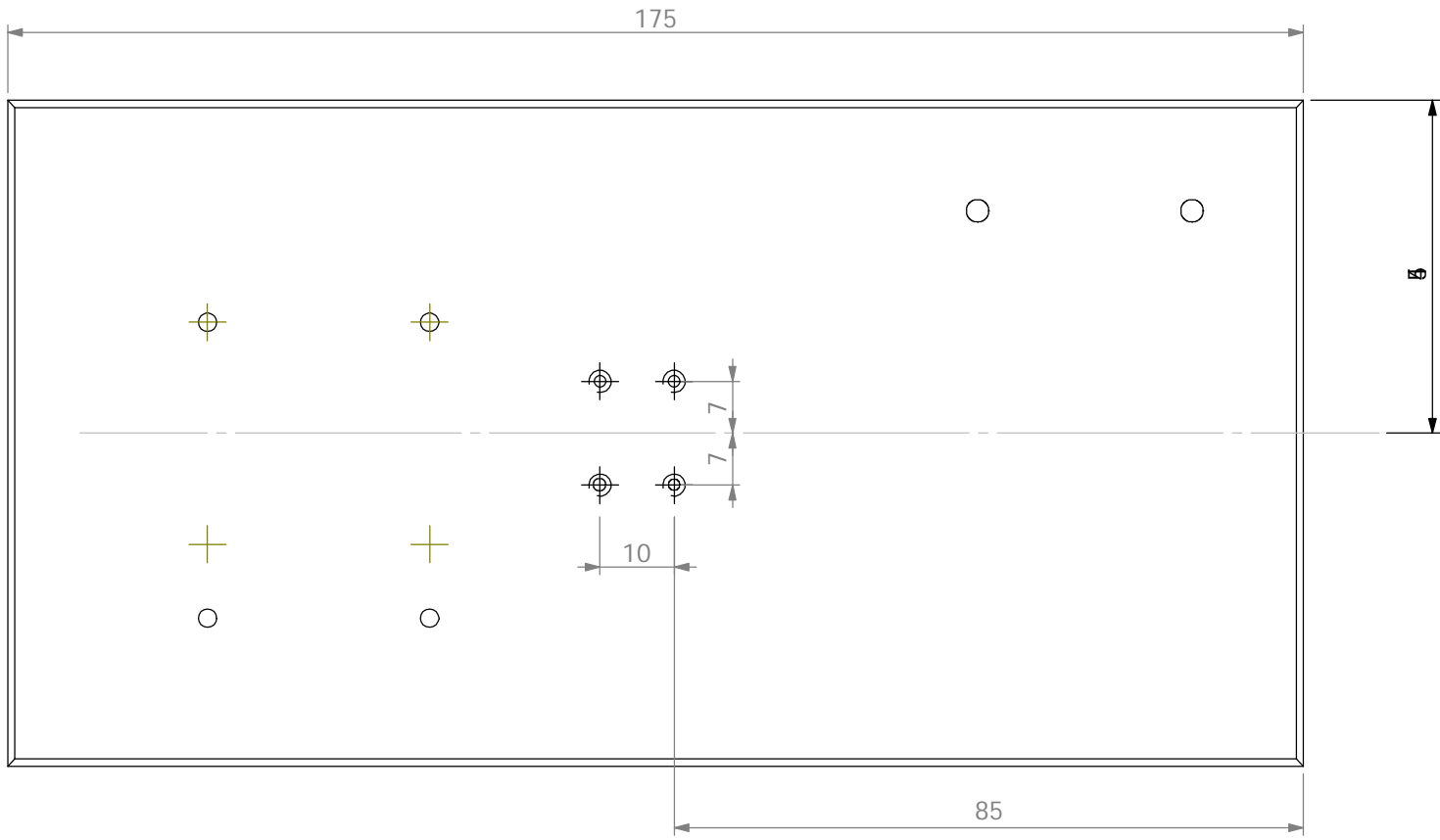

Socle

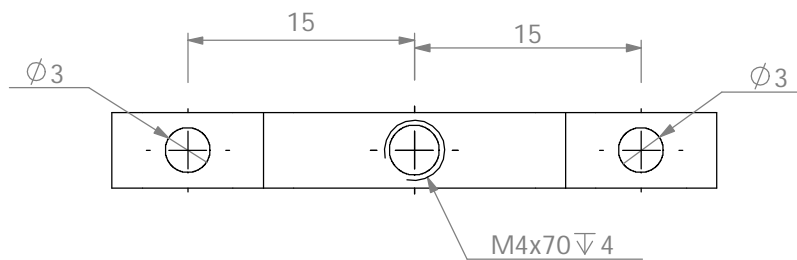
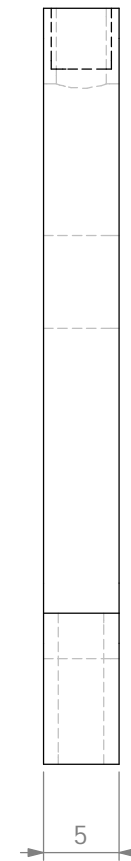
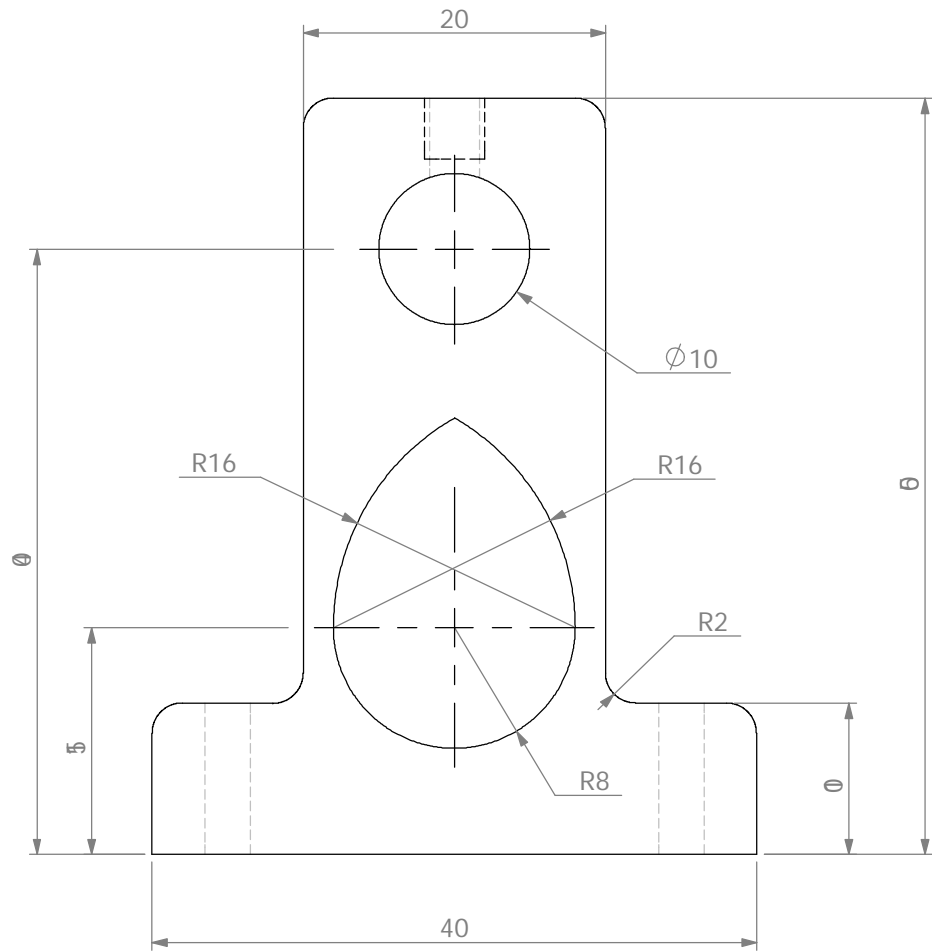

Support de vilebrequin

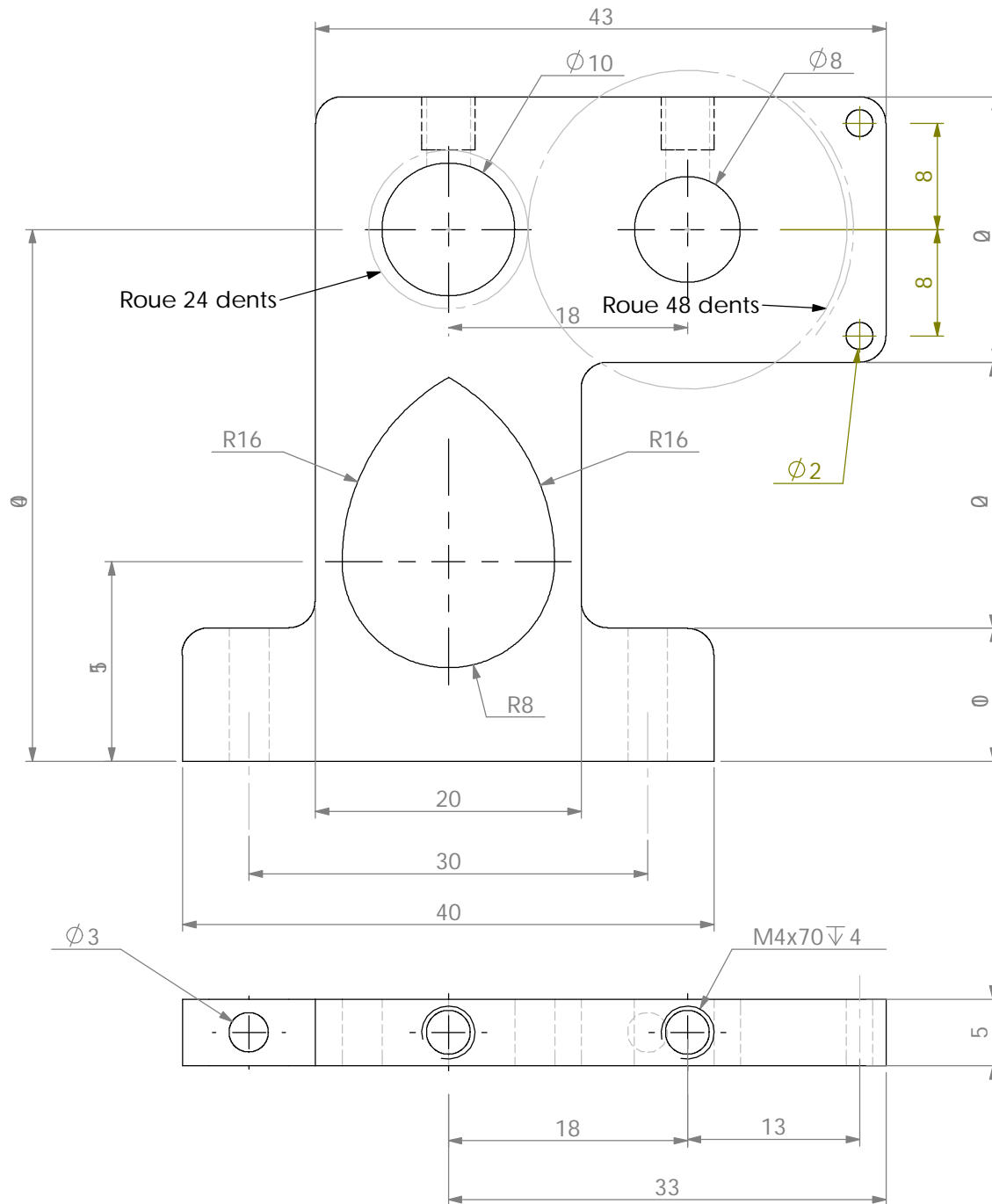

Support de distribution

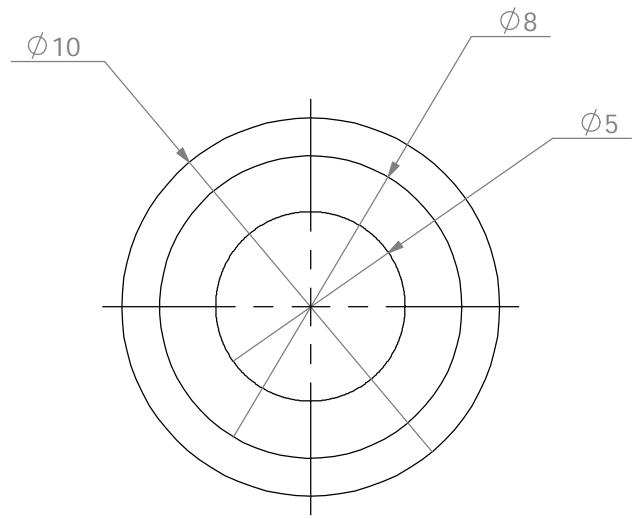

Coussinet d'engrenage de distribution  
1 piece bronze

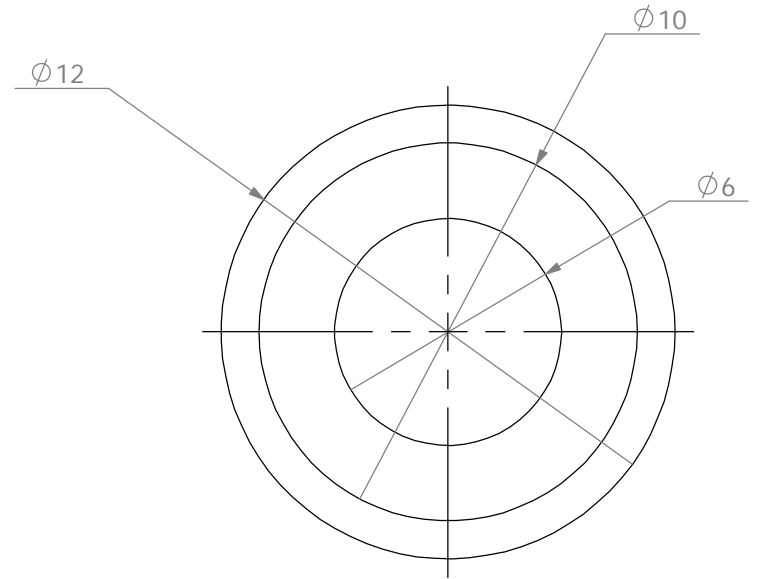

Coussinet de vilebrequin  
2 pieces bronze

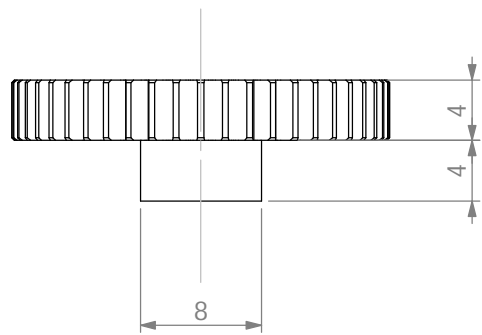
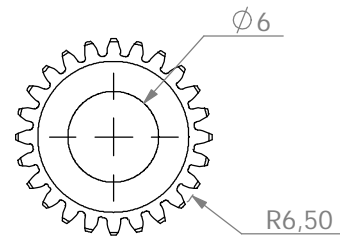
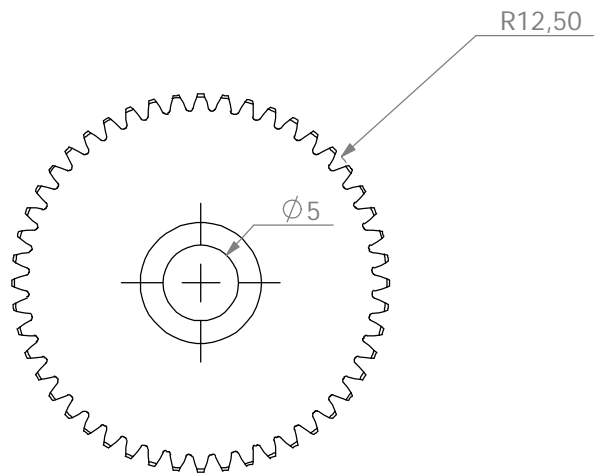

Engrenage 48 dents  
Mod. 0,5  
Diamètre nominal: 24 mm

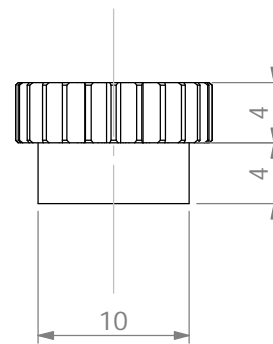

Engrenage 24 dents  
Mod. 0,5  
Diamètre nominal: 12 mm

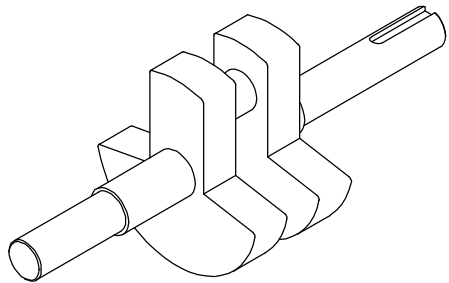
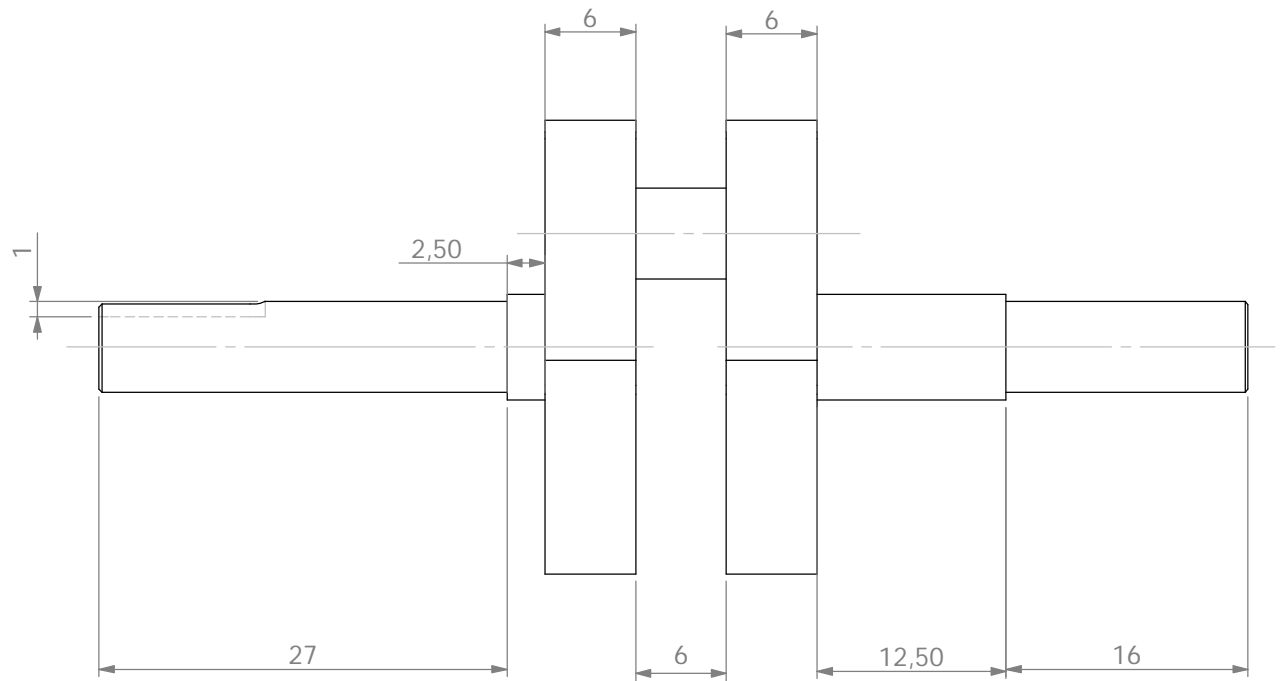
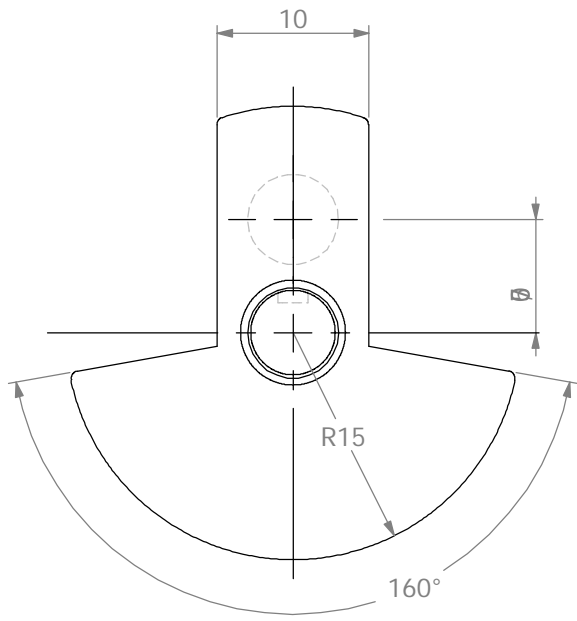

Vilebrequin

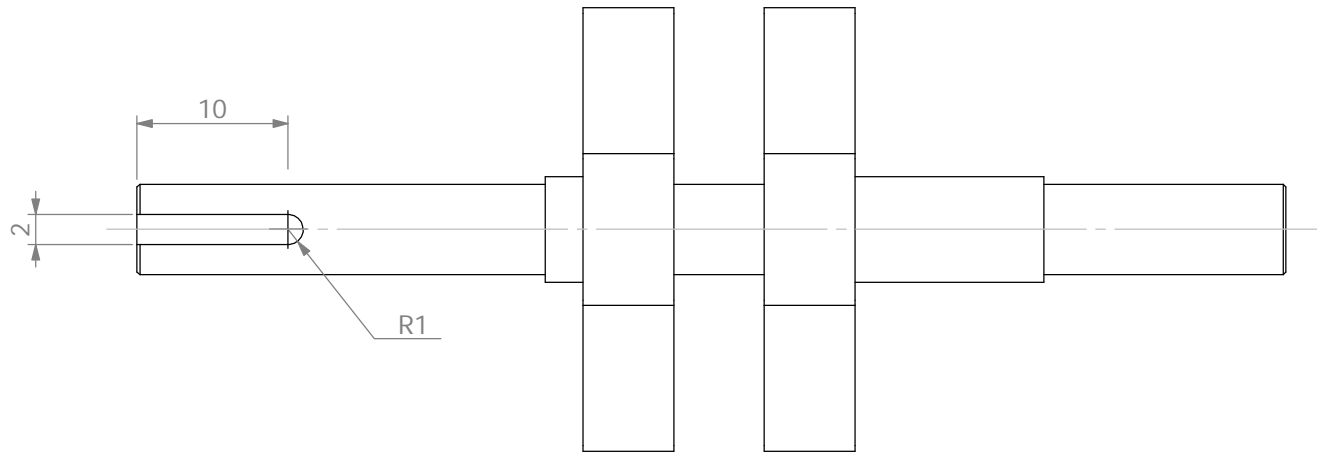

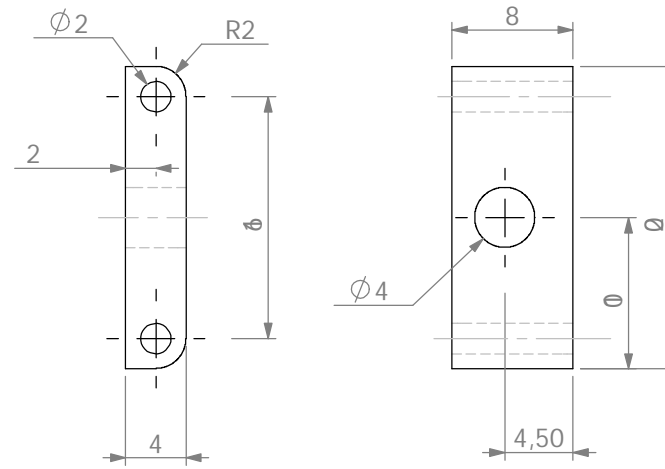
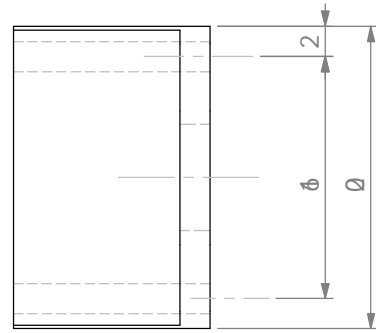
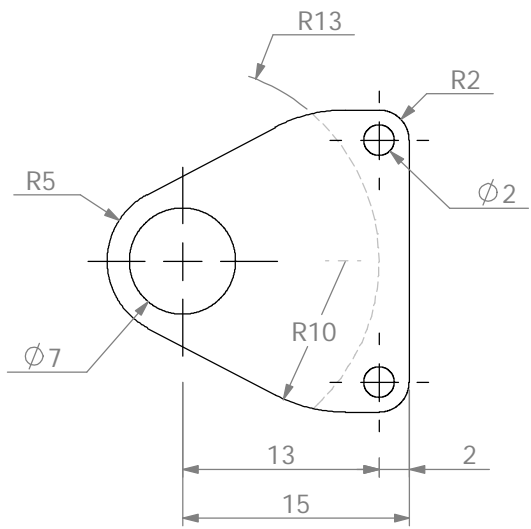

Support de glissière

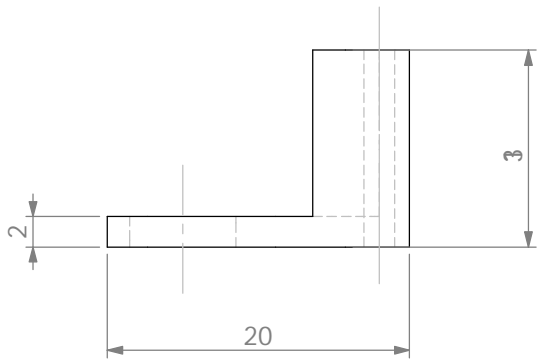

Etrier

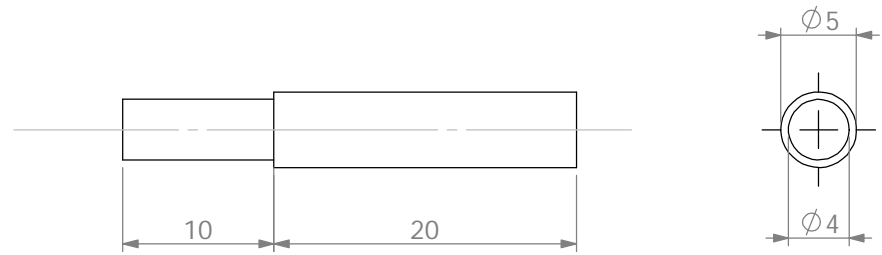

Axe de came

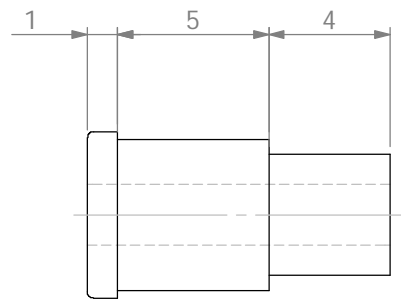
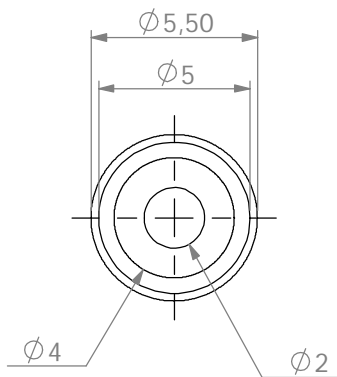

Glissière

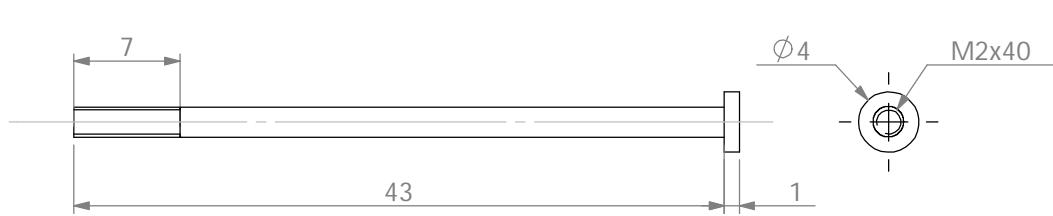

Tige de commande

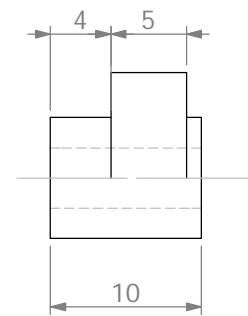
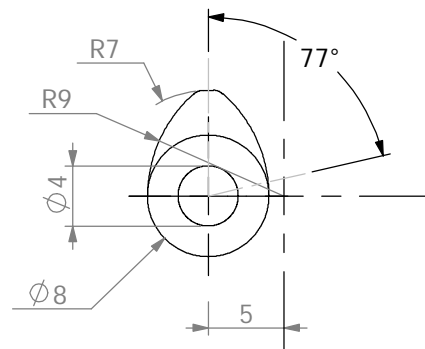

Came

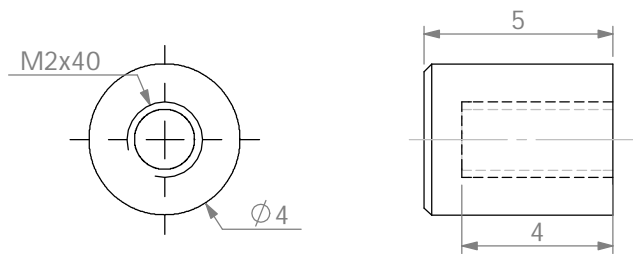
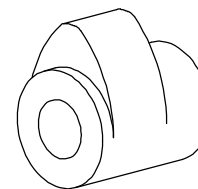

Poussoir

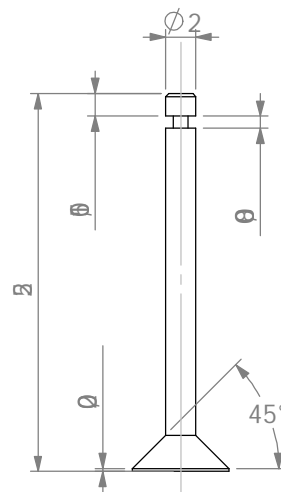

Soupape

