

## **CAUTION: ENGINE HAS NOT BEEN BUILT – THERE MAY BE MISTAKES**

*My intention was to have an engine that the intake and exhaust tubes were not visible. My plan was to make a small wooden stand and have the air/steam come in through the back of the box and up to the bottom of the engine. Below are just a few of my notes to explain what I tried to do with this design.*

### **MAIN FRAME**

*All of the 2.5 x 2.5 x .375 aluminum that I have seen has had the large radius be approx .250. I do not think that this differs much, but I believe that I have designed the frame to compensate for this. If this radius is less, you will have to compensate for the 10-32 hole. (Please see the MAIN FRAME drawing for details on this). The 10-32 hole is for mounting the frame to the stand. Make sure the 4-40 screw has a little play through the CYLINDER BUSHING and MAIN FRAME. If not, and hole is not a "perfect" 90 degree angle to the frame, the screw may keep the cylinder from contacting the frame fully. Be sure to polish the area that the cylinder contacts the frame.*

### **CRANKSHAFT**

*Location of cutout on shaft is not critical. My intention was to use this flat to adjust the flywheel for endplay for the crankshaft.*

### **CYLINDER BUSHING**

*My intention is to have the bushing to be a (light) press fit in the MAIN FRAME, and have a nice free fit for the cylinder. The builder could make this bushing different diameters if he wishes.*

### **CYLINDER**

*Polish the face that goes against the MAIN FRAME to keep friction low. The radius on the bottom of the cylinder is to clear the crankshaft as it rotates, otherwise the cylinder will hit the crankshaft as it oscillates back and forth. Care should be taken when you drill the 4-40 hole as it comes very close to the cylinder bore. The depth shown should be considered the maximum.*

### **FLYWHEEL**

*The 8, .218 diameter holes are strictly cosmetic. The outside diameter should be kept as shown as anything larger would make spring pressure adjustment more difficult.*

### **TUBE FITTINGS**

*Be sure to taper slightly the ends that are to be pressed into the MAIN FRAME. I have pressed thin walled pieces like this into aluminum with no problem. The guide can be out of any scrap material that you have on hand.*

### **AIR PASSAGE PLUG**

*The head diameter and thickness does not matter as this is just to press the part into the frame. This is to be filed or machined off after being pressed in. Be sure to undercut as shown to make sure the .063 length will be pressed in full depth.*

*Ernie Daniel*

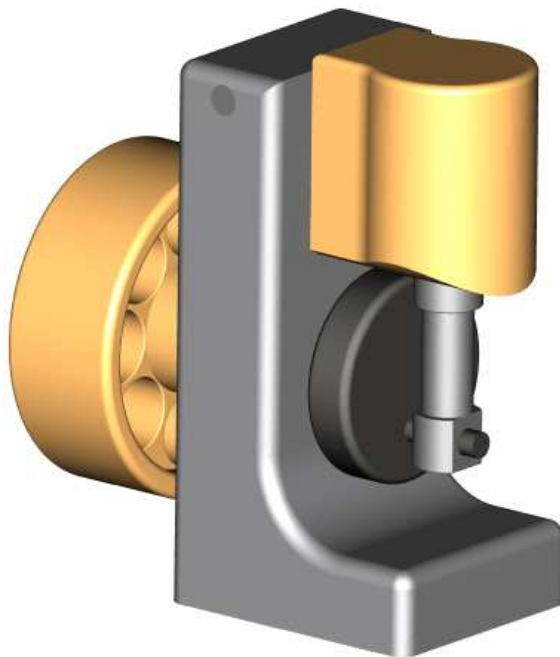

REVISION		
REV	DESCRIPTION	DATE

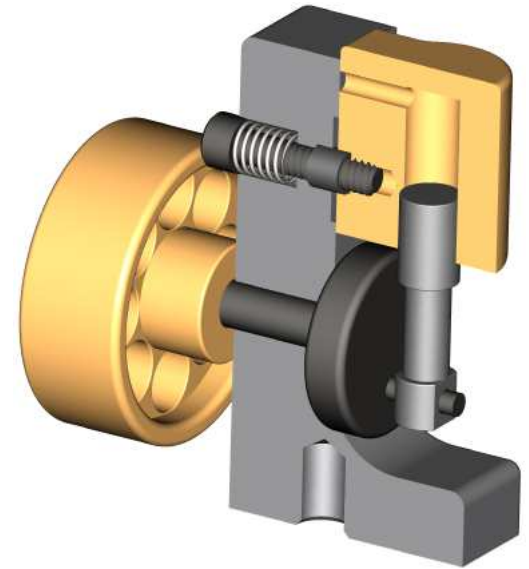
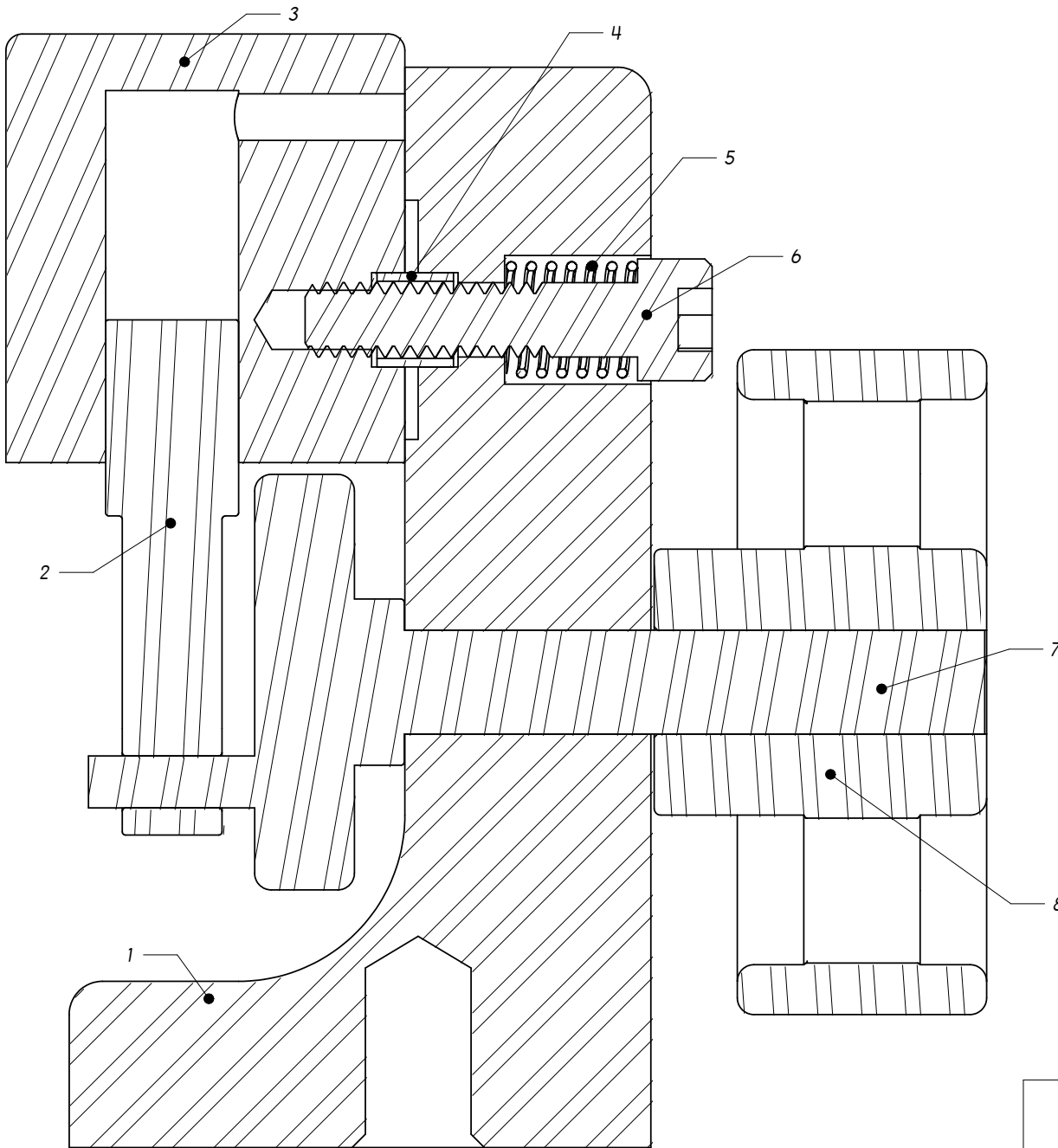

1. MAIN FRAME
2. PISTON
3. CYLINDER
4. CYLINDER BUSHING
5. SPRING -  $\varnothing .177 \times .25$
6. 4-40 x .500 SHCS
7. CRANKSHAFT
8. FLYWHEEL
9. 2-56 x .125 FP SS (not shown)
10. TUBE FITTINGS (not shown)
11. AIR PASSAGE PLUG (not shown)

NOTE:  
1. SOME LINES OMITTED FOR CLARITY

PROPRIETARY AND CONFIDENTIAL The information contained in this drawing is the sole property of Ernie Daniel. Any reproduction, in part or in whole, without the written permission of Ernie Daniel is prohibited.	UNLESS OTHERWISE STATED .xx $\pm$ .010 .xxx $\pm$ .003 .xxxx $\pm$ .001 ANGULAR $\pm 0^\circ 30'$ BREAK ALL EDGES DO NOT SCALE DRAWING	125 63 
--	--	---------------

## SP1 - WOBBLER

<b>SECTION VIEW</b>			
MATERIAL	SCALE 4 : 1	REV	DRAWN BY E. DANIEL

REVISION		
REV	DESCRIPTION	DATE

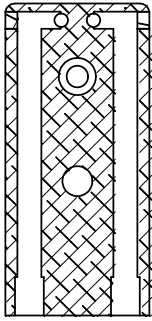

SECTION A-A

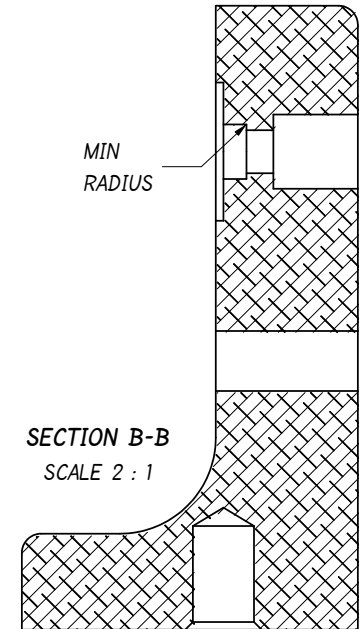
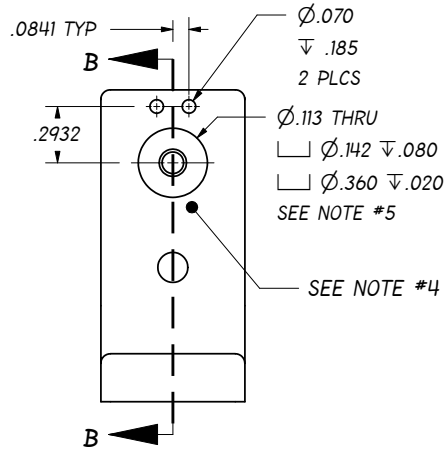
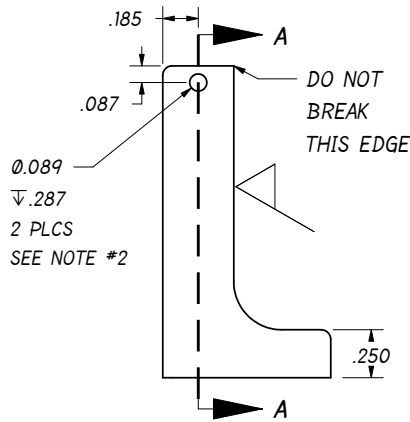
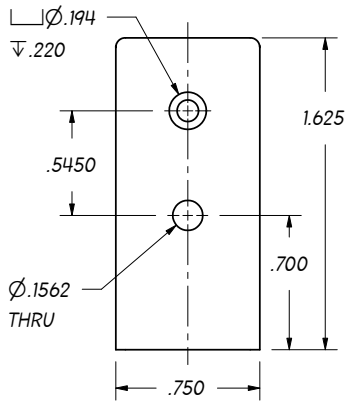
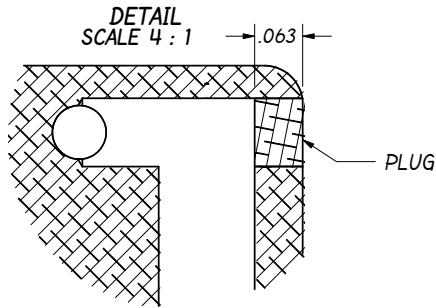

SECTION B-B  
SCALE 2:1

NOTE:

1. SOME LINES OMITTED FOR CLARITY
2. INSERT PLUG AFTER DRILLING - SEE DETAIL
3. MATERIAL - 2.5 x 2.5 x .375, 6061 ANGLE ALUMINUM
4. MINIMUM CLEANUP TO INSURE .365 - .375 THICKNESS  
POLISH AREA WHERE CYLINDER CONTACTS FRAME SURFACE
5. THE .142 DIA. DIMENSION TO BE A LIGHT PRESS FIT FOR THE CYLINDER BUSHING
6. THE .150 DIA DIMENSION TO BE A PRESS FIT FOR THE INTAKE AND EXHAUST TUBES

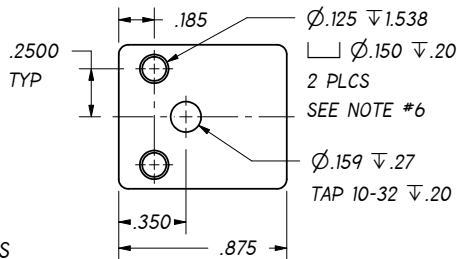

PROPRIETARY AND CONFIDENTIAL  
The information contained in this drawing is the sole property of Ernie Daniel. Any reproduction, in part or in whole, without the written permission of Ernie Daniel is prohibited.

UNLESS OTHERWISE STATED  
.xx ± .010  
.xxx ± .003  
.xxxx ± .001  
ANGULAR ± 0° 30'  
BREAK ALL EDGES  
DO NOT SCALE DRAWING



# SP1 - WOBBLER

## MAIN FRAME

MATERIAL	SEE NOTES	SCALE	1:1	REV	DRAWN BY	E. DANIEL
----------	-----------	-------	-----	-----	----------	-----------

REVISION		
REV	DESCRIPTION	DATE

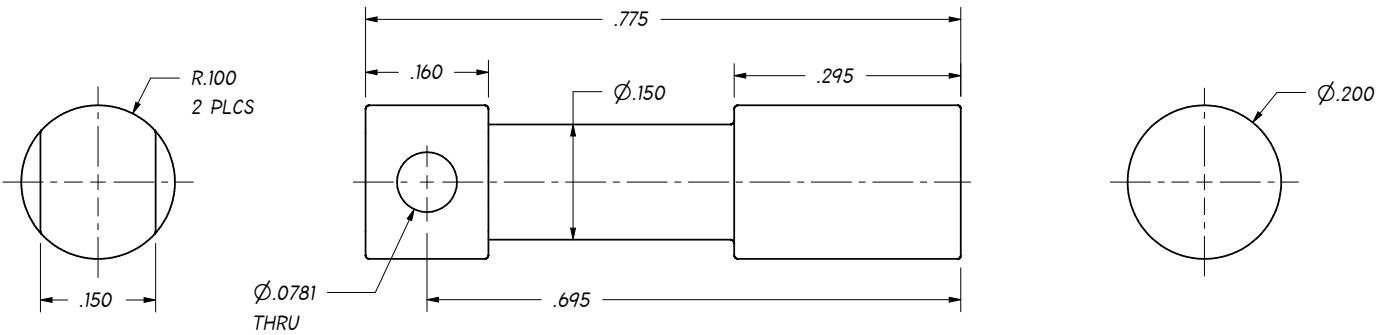

- NOTE:
1. SOME LINES OMITTED FOR CLARITY
  2. MINIMUM EDGE BREAK ALL CORNERS
  3. LAP PISTON TO FIT CYLINDER BORE

PROPRIETARY AND CONFIDENTIAL

The information contained in this drawing is the sole property of Ernie Daniel. Any reproduction, in part or in whole, without the written permission of Ernie Daniel is prohibited.

UNLESS OTHERWISE STATED

.xx ± .010  
 .xxx ± .003  
 .xxxx ± .001

ANGULAR ± 0° 30'  
 BREAK ALL EDGES  
 DO NOT SCALE DRAWING

**SP1 - WOBBLER**

<b>PISTON</b>			
MATERIAL	ALUMINUM	SCALE 4 : 1	REV
		DRAWN BY	E. DANIEL

REVISION		
REV	DESCRIPTION	DATE

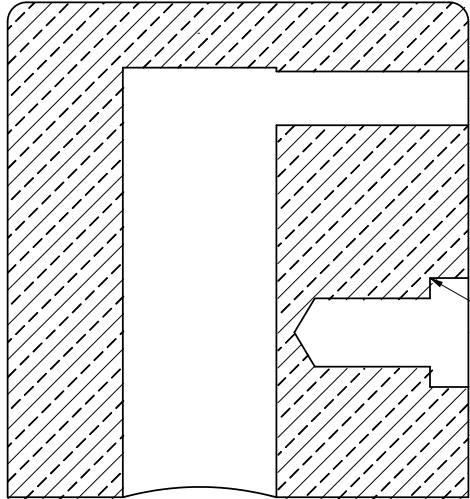
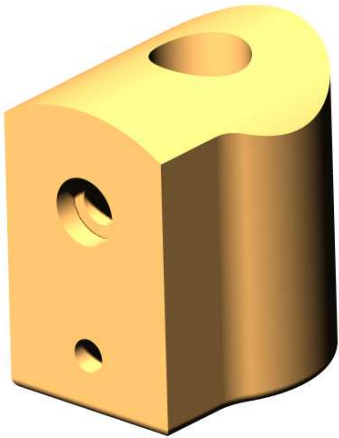

SCALE 4 : 1

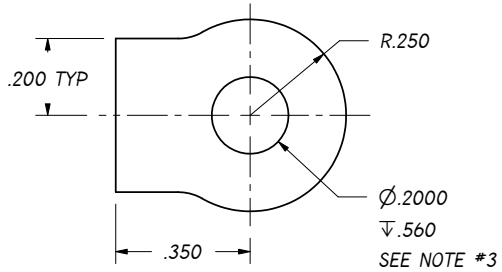
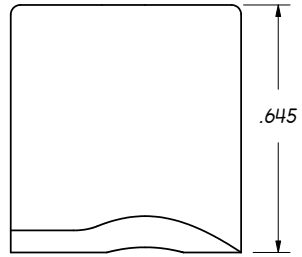
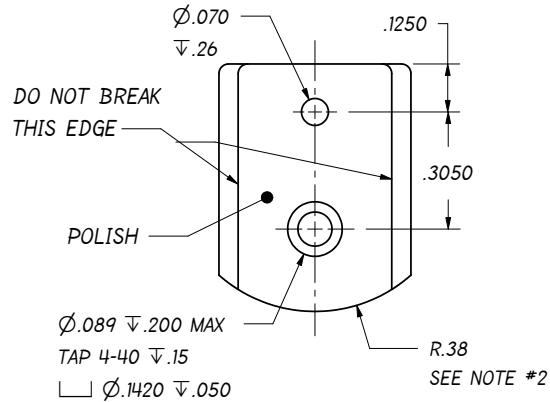

NOTE:

1. SOME LINES OMITTED FOR CLARITY
2. RADIUS REQUIRED TO CLEAR .625 DIAMETER ON CRANKSHAFT
3. LAP BORE TO FIT PISTON

PROPRIETARY AND CONFIDENTIAL	UNLESS OTHERWISE STATED .xx ± .010 .xxx ± .003 .xxxx ± .001 ANGULAR ± 0° 30' BREAK ALL EDGES DO NOT SCALE DRAWING
The information contained in this drawing is the sole property of Ernie Daniel. Any reproduction, in part or in whole, without the written permission of Ernie Daniel is prohibited.	

<b>SP1 - WOBBLER</b>			
<b>CYLINDER</b>			
MATERIAL	BRASS	SCALE 2 : 1	REV
DRAWN BY		E. DANIEL	

REVISION		
REV	DESCRIPTION	DATE

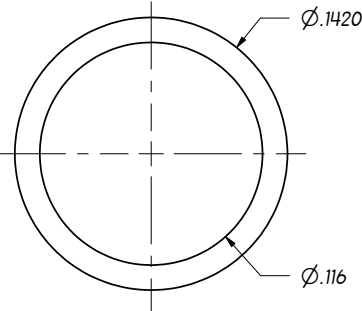
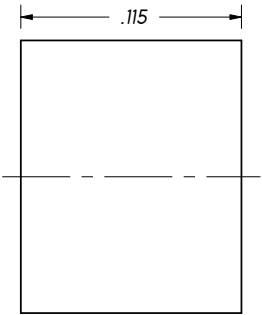

NOTE:  
1. SOME LINES OMITTED FOR CLARITY

PROPRIETARY  
AND  
CONFIDENTIAL  
The information contained in this drawing is the sole property of Ernie Daniel. Any reproduction, in part or in whole, without the written permission of Ernie Daniel is prohibited.

UNLESS OTHERWISE STATED  
.xx ± .010  
.xxx ± .003  
.xxxx ± .001  
ANGULAR ± 0° 30'  
BREAK ALL EDGES  
DO NOT SCALE DRAWING



SP1 - WOBBLER

CYLINDER BUSHING

MATERIAL	STEEL	SCALE	10 : 1	REV	DRAWN BY	E. DANIEL
----------	-------	-------	--------	-----	----------	-----------

REVISION		
REV	DESCRIPTION	DATE

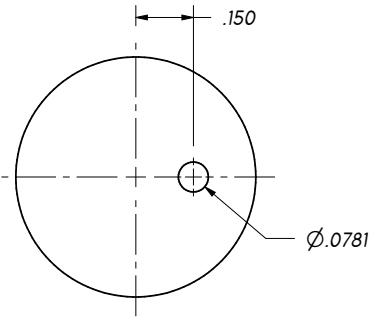
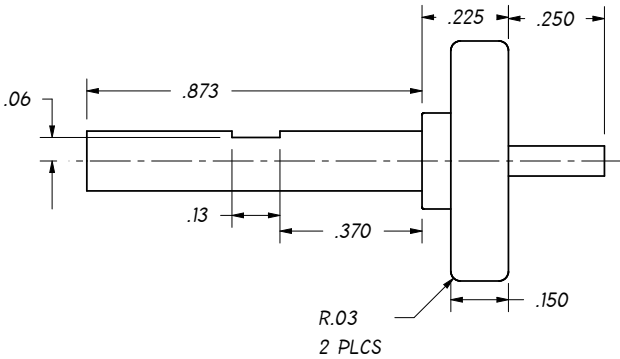
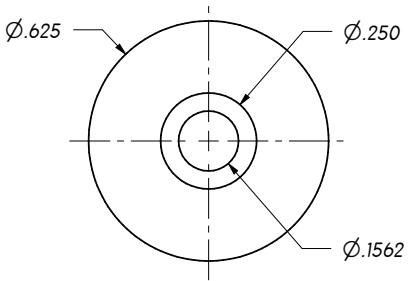
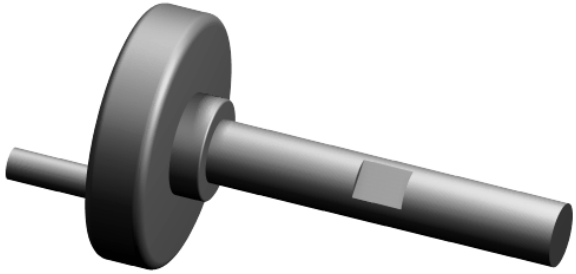

NOTE:  
 1. SOME LINES OMITTED FOR CLARITY  
 2. MAY BE MACHINED AS ONE PIECE, OR MACHINED AS TWO PIECES, THEN PRESSED OR SOLDERED TOGETHER

<b>PROPRIETARY AND CONFIDENTIAL</b> The information contained in this drawing is the sole property of Ernie Daniel. Any reproduction, in part or in whole, without the written permission of Ernie Daniel is prohibited.	<b>UNLESS OTHERWISE STATED</b> .xx ± .010 .xxx ± .003 .xxxx ± .001 ANGULAR ± 0° 30' BREAK ALL EDGES DO NOT SCALE DRAWING
---	--

# SP1 - WOBBLER

# CRANKSHAFT

MATERIAL	STEEL	SCALE	2 : 1	REV	DRAWN BY	E. DANIEL
----------	-------	-------	-------	-----	----------	-----------

REVISION		
REV	DESCRIPTION	DATE

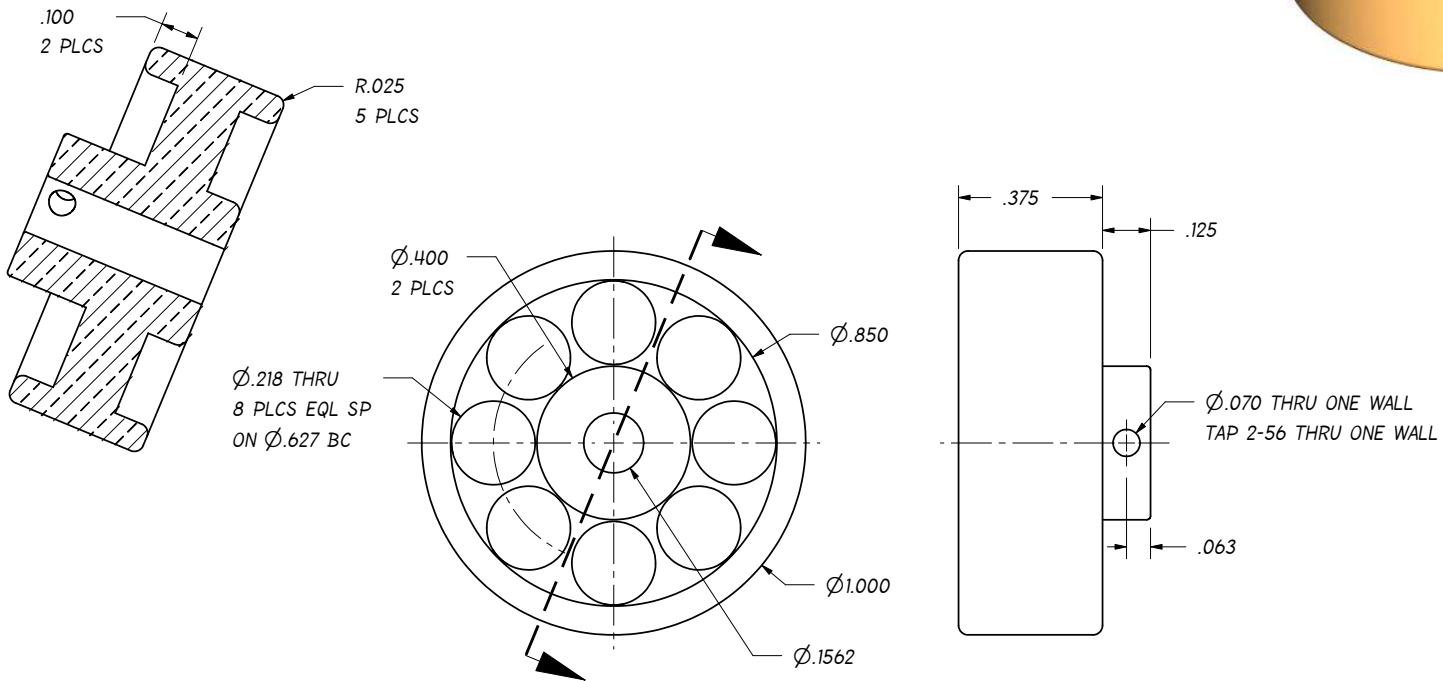
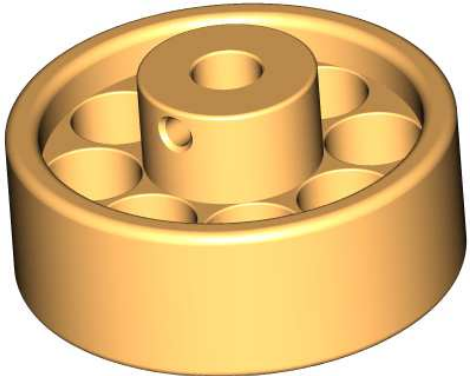

NOTE:  
 1. SOME LINES OMITTED FOR CLARITY  
 2. ONE 2-56 x .125 FLAT POINT SET SCREW REQUIRED FOR ASSEMBLY

<b>PROPRIETARY AND CONFIDENTIAL</b> The information contained in this drawing is the sole property of Ernie Daniel. Any reproduction, in part or in whole, without the written permission of Ernie Daniel is prohibited.	<b>UNLESS OTHERWISE STATED</b> .xx ± .010 .xxx ± .003 .xxxx ± .001 ANGULAR ± 0° 30' BREAK ALL EDGES DO NOT SCALE DRAWING	125 63 
---	--	---------------

<b>SP1 - WOBBLER</b>			
<b>FLYWHEEL</b>			
MATERIAL	BRASS	SCALE	2 : 1
REV		DRAWN BY	E. DANIEL

REVISION		
REV	DESCRIPTION	DATE

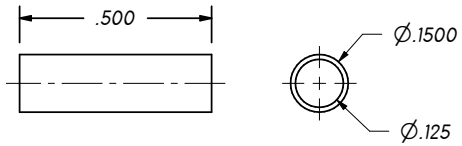
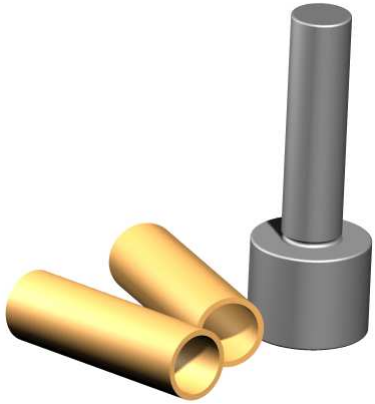

**TUBE FITTING**  
BRASS

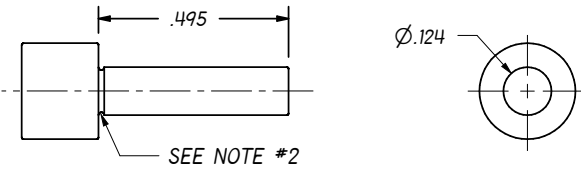

**TUBE FITTING GUIDE**  
ALUMINUM

**NOTE:**

1. SOME LINES OMITTED FOR CLARITY
2. UNDERCUT TO INSURE 90 DEGREE CORNER
3. TWO TUBE FITTINGS REQUIRED FOR INTAKE AND EXHAUST

<b>PROPRIETARY AND CONFIDENTIAL</b> The information contained in this drawing is the sole property of Ernie Daniel. Any reproduction, in part or in whole, without the written permission of Ernie Daniel is prohibited.	<b>UNLESS OTHERWISE STATED</b> .xx ± .010 .xxx ± .003 .xxxx ± .001 ANGULAR ± 0° 30' BREAK ALL EDGES DO NOT SCALE DRAWING	
---	--	--

**SP1 - WOBBLER**

**TUBE FITTINGS**

MATERIAL	SCALE 2 : 1	REV	DRAWN BY E. DANIEL
----------	-------------	-----	--------------------

REVISION		
REV	DESCRIPTION	DATE

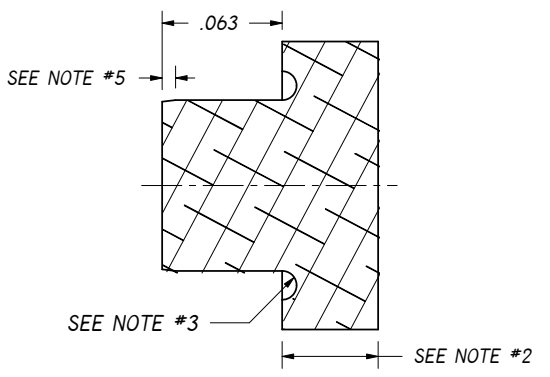
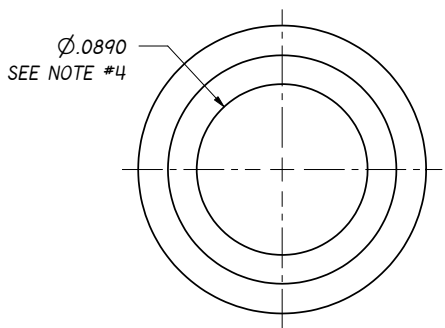
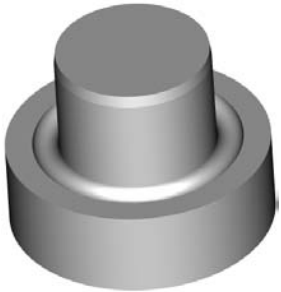

- NOTE:
1. SOME LINES OMITTED FOR CLARITY
  2. TO BE FILED OR MACHINED OFF AFTER PLUG IS PRESSED IN
  3. UNDERCUT TO INSURE 90 DEGREE CORNER
  4. TO BE A PRESS FIT INTO MAIN FRAME
  5. SLIGHT TAPER TO INSURE PROPER ALIGNMENT

PROPRIETARY AND CONFIDENTIAL  
 The information contained in this drawing is the sole property of Ernie Daniel. Any reproduction, in part or in whole, without the written permission of Ernie Daniel is prohibited.

UNLESS OTHERWISE STATED  
 .xx ± .010  
 .xxx ± .003  
 .xxxx ± .001  
 ANGULAR ± 0° 30'  
 BREAK ALL EDGES  
 DO NOT SCALE DRAWING



<b>SP1 - WOBBLER</b>			
<b>AIR PASSAGE PLUG</b>			
MATERIAL	ALUMINUM	SCALE	10 : 1
REV		DRAWN BY	E. DANIEL